

The Application of Volterra Functional Series to Non-Linear Rotor-Shaft Vibration System

Tegoeh Tjahjowidodo, Komang Bagiasna, Zainal Abidin
Laboratorium Dinamika, PPAUIR – ITB
Jalan Ganesha 10, Bandung 40132
Telp./Fax. 022-2506283
E-mail: tegoeh@dynamic.pauir.itb.ac.id

Abstract

The Volterra kernels of non-linear systems have been studied for some time now. The multidimensional Fourier transform of Volterra kernels results the higher order Frequency Response Functions (FRF's) of the system. These can predict aspect of the nonlinear system behavior unobtainable from the conventional first order FRF (linear FRF), which is for a non-linear system represents linearisation of the system. The rotor-bearing system, which is studied in this research, is an experimental set up that was built to study the non-linear phenomenon. Many researches have been studied the dynamic characteristic of continuous rotor-bearing system using Modal Analysis and pseudo-modal method. Unfortunately, those researches never consider the nonlinear aspect of the system. Rolling element bearing as one of the main component of the rotor-bearing system has been widely known to have non-linear stiffness. Based on the assumption that the nonlinearity behavior was possessed by the rolling element bearing only, then the non-linear response of the system can be predicted. The more accurate prediction of the response can be obtained using modal analysis method that is modified by Volterra functional series theory then using linearised-system method.

Keywords: *Volterra kernel, multidimensional Fourier transforms, frequency response function*

Introduction

Turbomachinery is widely used in the processing based industry. The main components of this type of machinery is a rotor-shaft and its supporting system which have a predominant role as a vibration system. Some of the rotating components of the system have non-linear property. This is due to the fact there are many harmonic signals appeared on the observation of the system vibration response when it is rotated on a certain frequency.

One of the main components in rotor-shaft system is ball bearing, which is used to support the rotating components. Many researchers confirmed that ball bearing has non-linear stiffness. This non-linearity affects the whole dynamic characteristic of the rotor-shaft system. The model of non-linear response of the rotor-shaft vibration system is based on the assumption that non-linearity of the system is dominated by the ball-bearing characteristic.

The Volterra Functional Series that is used to predict response of non-linear vibration have been widely developed for some time now. By modeling the Volterra kernels and the higher

order Frequency Response Functions (FRF's) then the vibration response due to a certain excitation can be predicted.

Modeling of the Volterra kernels and the higher order FRF's of rotor-shaft vibration system is carried out by utilizing modal analysis method and Finite Rotating Element method. The main objective of this research is to combine both methods mentioned above with the Volterra Functional Series in application of predicting the non-linear vibration response in the rotor-shaft system.

Finite Rotating Element Method

In this research activities, the finite rotating element method was utilized to predict the dynamic characteristic of the rotor-shaft system. The applied method considers three main components that make up rotor-shaft system, i.e.: disk (rotor), shaft and bearing. Beside those components, previous researches[10] has shown that dynamic characteristics of overall system are heavily influenced by the support structures, thus support structures of the rotor-shaft system can not be neglected in vibration response prediction.

In order to consider the influence of the support-structures on overall system, then the modal parameters of some supporting-structures should be obtained. These parameters will be used to modify element matrices, which are needed for finite element modeling. The modeled structures of the rotor-shaft system, including the support structures is shown in Figure 1.

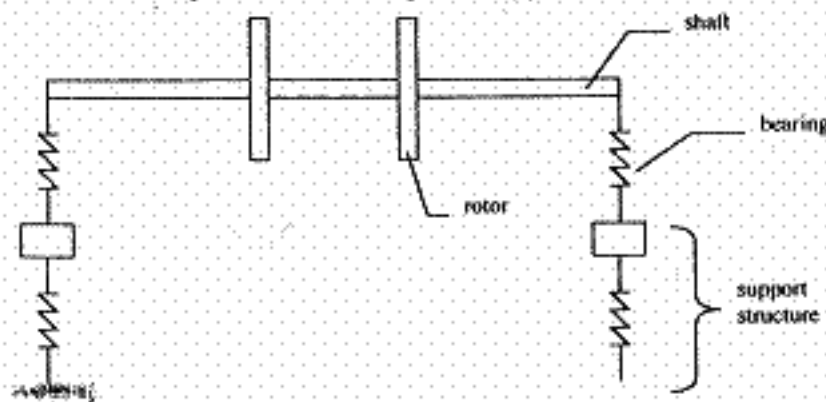

Figure 1. Rotor-shaft system model

Experimental FRF of support structures showed that the structure has two mode shapes along the span frequency of measurement. According to the measured FRF, one can apply two kinds of curve-fitting method, i.e.: 1-DOF (Single Degree of Freedom) and 2-DOF (Two Degrees of Freedom) curve-fitting methods. Figure 2 and Figure 3 show the FRF measurement of the support structure and the typical obtained curve-fitting process both for single-DOF and two-DOF respectively.

By using curve-fitting technique available in Matlab® software package, the dynamic parameters of the support-structure, i.e.: modal mass, modal stiffness and modal damping can be obtained. Afterwards, those dynamic parameters will be used to modify the element matrices, which are needed in the finite rotating element method.

Figure 4, 5 and 6 show the comparison between FRF obtained from the theoretical modeling and from the experimental one. Figure 4 and Figure 5 show the estimated FRF of the rotor-shaft system, which was calculated by using finite element method that has been modified by introducing the support-structures of the rotor-shaft system, while Figure 6 shows the FRF curve obtained from the measurements using shock excitation method.

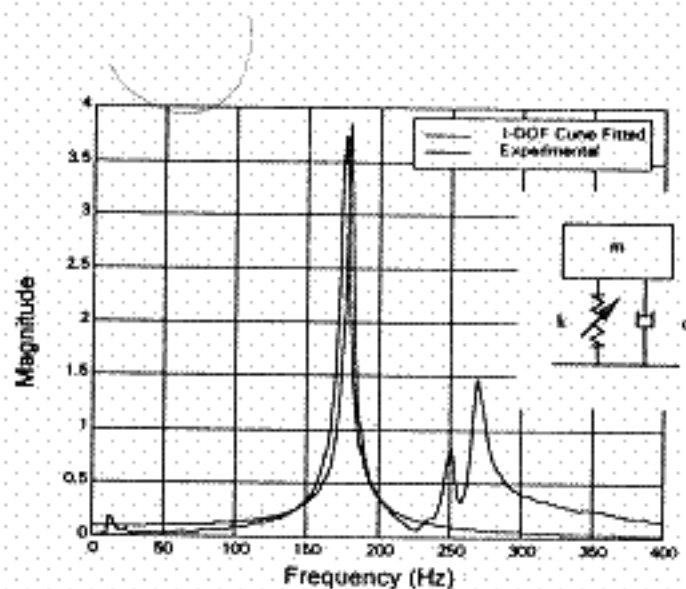

Figure 2. Single DOF curve-fitting of FRF Support Structure

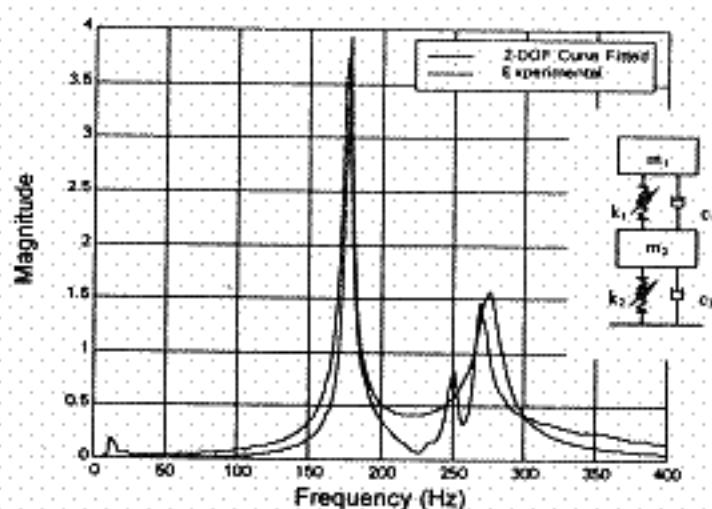

Figure 3. Two DOF curve-fitting of FRF Support Structure

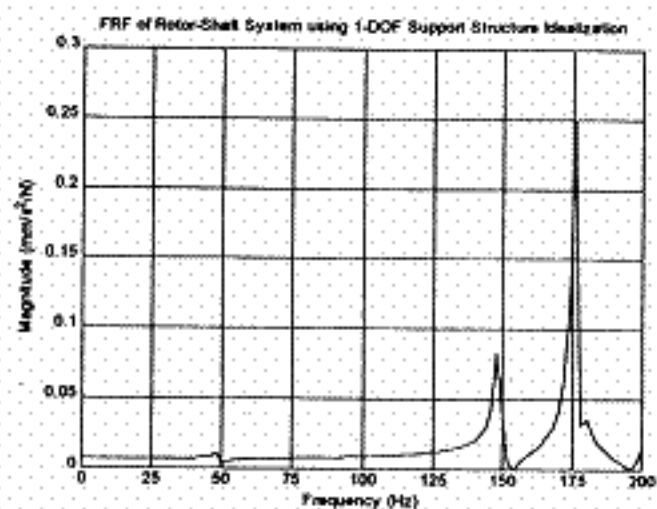

Figure 4. Estimated FRF of Rotor-Shaft system using 1-DOF Support-Structure model

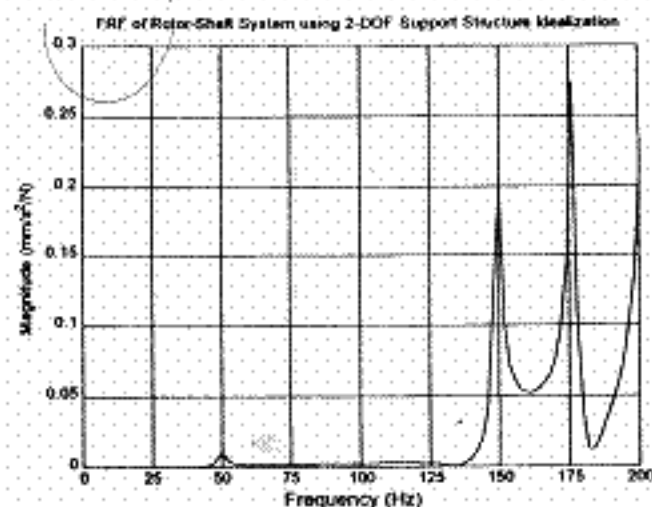

Figure 5. Estimated FRF of Rotor-Shaft system using 2-DOF Support-Structure model

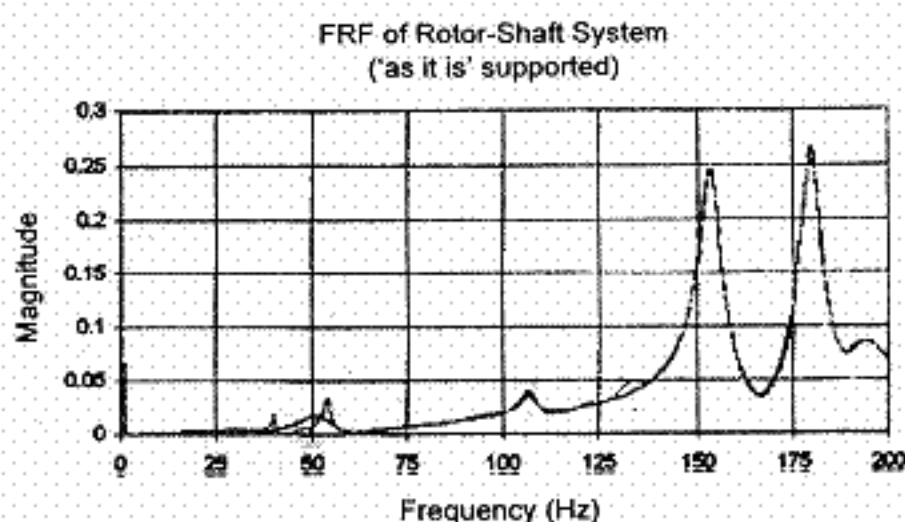

Figure 6. Experimental FRF of Rotor-Shaft system

Based on the above figures (4, 5 and 6), the estimated FRF's from modeling show good agreement to the experimental data. Although the higher degree-of-freedom model of the support-structures as shown in Figure 5 shows better agreement to the experimental data, both models indicate no significant difference. Therefore, for the sake of simplicity, 1-DOF support-structure model will be used to evaluate the higher-order FRF, which will be discussed in the next paragraph.

Volterra Functional Series

The relationship between an input x and an output y for a non-linear time-invariant system can be expressed as [10]:

$$\begin{aligned}
 y(t) = & \int_{-\infty}^{\infty} h_1(\tau_1) x(t - \tau_1) d\tau_1 + \int_{-\infty}^{\infty} \int_{-\infty}^{\infty} h_2(\tau_1, \tau_2) x(t - \tau_1) x(t - \tau_2) d\tau_1 d\tau_2 \\
 & + \int_{-\infty}^{\infty} \int_{-\infty}^{\infty} \int_{-\infty}^{\infty} h_3(\tau_1, \tau_2, \tau_3) x(t - \tau_1) x(t - \tau_2) x(t - \tau_3) d\tau_1 d\tau_2 d\tau_3 \\
 & + \dots + \int_{-\infty}^{\infty} \dots \int_{-\infty}^{\infty} h_n(\tau_1, \tau_2, \dots, \tau_n) x(t - \tau_1) x(t - \tau_2) \dots x(t - \tau_n) d\tau_1 \dots d\tau_n + \dots
 \end{aligned}$$

Equation (1) above is called the Volterra Functional Series, and the function h_0, h_1, \dots are called the Volterra kernels of the system. For a linear system, all kernels except h_1 are zero and the series is reduced to the convolution integral of $x(t)$ with the impulse response h_1 . A linear system can be characterized by its impulse response function. Therefore, in the same way, a non-linear system could be completely characterized by all Volterra kernels. Practically, one can not deal with all kernels, so the series has to be truncated, usually to h_1 and h_2 only.

Regarding to the conventional linear-FRF, the Volterra series extends the familiar concept of the convolution integral. In the analysis of linear systems, the relationship between the impulse response function $h(\tau)$ and the FRF $H(\omega)$ is already well known using Fourier Transform. An equivalent relationship can be defined for the corresponding Volterra kernels in the Volterra series, again by using Multi-Dimensional Fourier Transform, as shown in equation (2).

$$H_n(j\omega_1, \dots, j\omega_n) = \int_{-\infty}^{\infty} \dots \int_{-\infty}^{\infty} h_n(\tau_1, \dots, \tau_n) e^{-j(\omega_1\tau_1 + \dots + \omega_n\tau_n)} d\tau_1 \dots d\tau_n \quad (2)$$

The multi-dimensional higher order FRF's can be used to explain how systems are excited by a broadband random signal, or in a simple manner by a multi-frequency excitation. As an illustration, let us consider a two-order system with a two-tone excitation input ω_a and ω_b . The output can be expressed as follows:

$$\begin{aligned} y_2(t) &= H_2[x_a + x_{-a} + x_b + x_{-b}] = \\ &= H_2[x_a] + H_2[x_{-a}] + H_2[x_b] + H_2[x_{-b}] + 2H_2\{x_a, x_{-a}\} + 2H_2\{x_b, x_{-b}\} \\ &\quad + 2H_2\{x_a, x_{-b}\} + 2H_2\{x_{-a}, x_b\} + 2H_2\{x_{-a}, x_{-b}\} + 2H_2\{x_a, x_b\} \end{aligned} \quad (3)$$

According to the output as shown in equation (3) above, the output can be concluded to have a form as a superposition of the response of each input, and the response, which are formed by the summation of each input-frequency (the last four terms). This phenomenon is called as *inter-modulation*.

Higher Order FRF of Multi-Degree of Freedom System

An N-degree of freedom system can be physically represented by N point masses, interconnected and grounded by N(N+1) springs and dampers. Each mass represents one degree of freedom as shown in Figure 7.

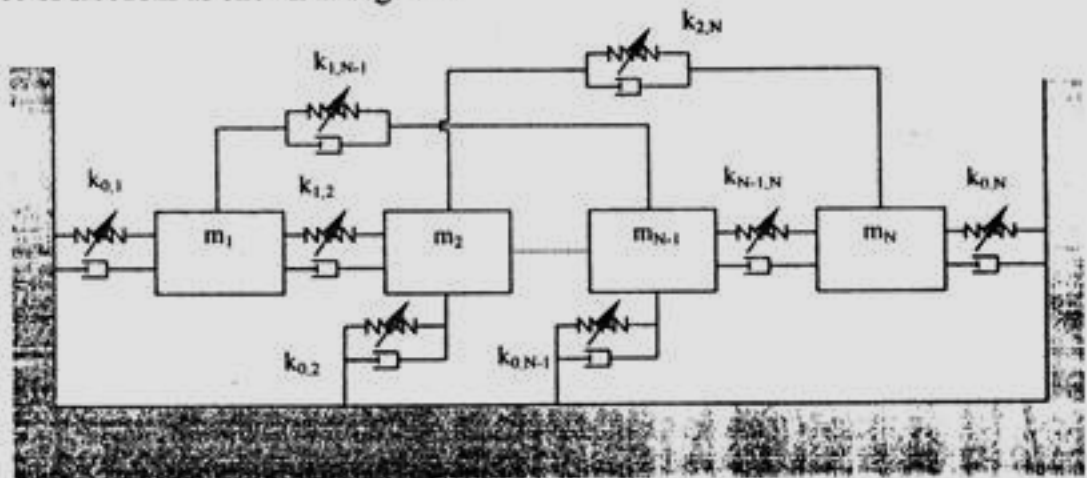

Figure 7. Non-linear multi-degree of freedom vibration system

The higher-order FRF of a multi-degree of freedom system can be obtained by evaluating this following equation [10]:

$$\left[{}^1H_{rs}(\omega_1 + \dots + \omega_N) \right]^{-1} \begin{Bmatrix} N H_{r1} \\ N H_{r2} \\ \dots \\ N H_{rs} \end{Bmatrix} = -\{\text{non-linear terms}\} \quad (4)$$

The subscript s represents point of applied force input, while subscript r represents point of measured displacement. It can be inferred based on equation (4) above, that the higher-order FRF is completely expressed by the set of first order FRF and the coefficients of higher-order terms in the stiffness polynomial function.

Result and Discussion

By using first-order FRF, which is obtained from finite rotating element method and support-structures model, the higher-order FRF can be predicted. Typical results obtained from this analysis are shown in Figure 8, Figure 9 and Figure 10.

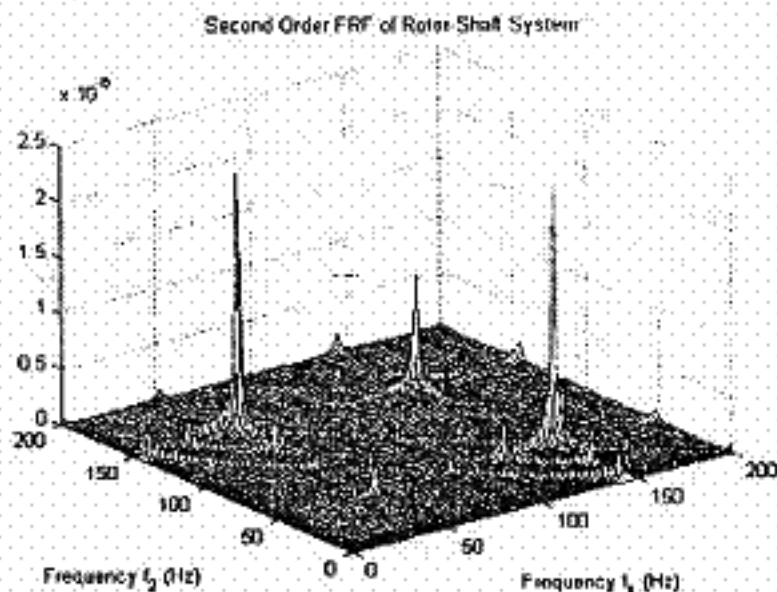

Figure 8. Second-order FRF of the rotor-shaft system

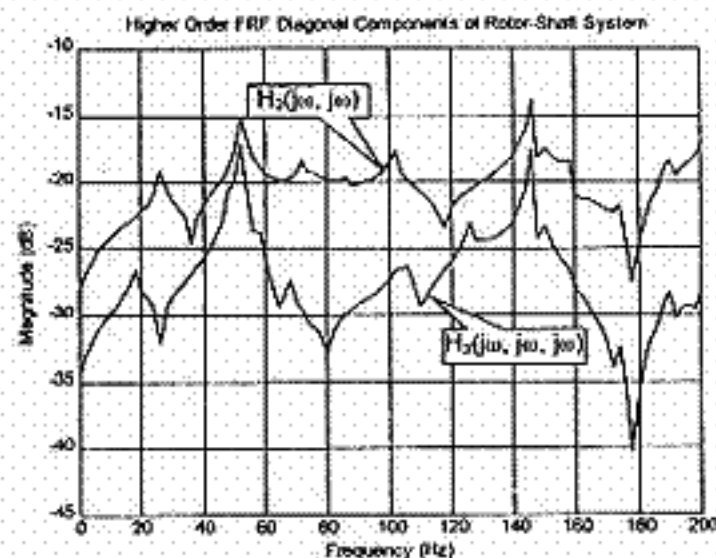

Figure 9. Component of 2nd-Order FRF and 3rd-Order FRF

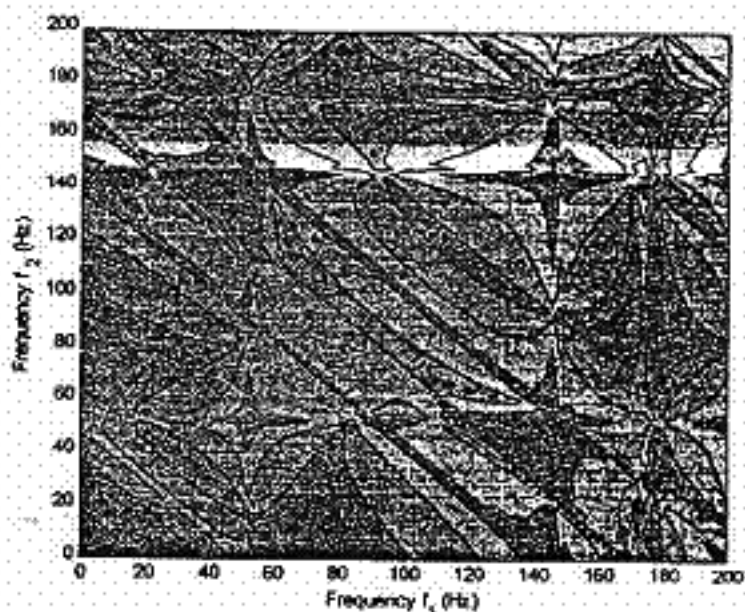

Figure 10. Contour of Second-Order FRF in dB scale

Based on FRFs of the rotor-shaft system, which are shown in figures above, response of the system excited at certain frequencies can be predicted. Generally speaking, rotor-shaft system usually are excited by two kinds of excitation, i.e.: unbalance, -which is characterized by response at $1 \times \text{Rpm}$ -, and misalignment, -usually characterized by response at $1 \times \text{Rpm}$ and $2 \times \text{Rpm}$ -. The Volterra Functional Series is carried out to simulate vibration response due to the existence of unbalance mass and misalignment.

Figure 11 shows result of theoretical analysis of response that caused by unbalance and misalignment, which is produced by adding a 80 gram mass to the rotor and rotate the system at 20 Hz. According to the figure, it can be seen that the response has some harmonic-frequency components. Mathematically, those harmonic components are resulted by higher-order Volterra kernels and effect of inter-modulation. To verify the theoretical result, an experimental testing has been conducted as shown in Figure 12. The test is conducted by applying the similar condition with theoretical model.

The next modeling is performed with applying excitation force caused by 80 grams unbalance mass and 26 Hz rotation speed. Theoretical and experimental result can be seen respectively in Figure 13 and Figure 14.

Conclusion

Based on the results obtained from the theoretical and experimental activities the following conclusions can be drawn as follows:

1. Higher-order degree of freedom that is introduced to the support-structure model yields a closer agreement results between the theoretical and the experimental FRFs of the full-scale rotor-shaft system.
2. The application of Volterra Functional Series to Finite Rotating Element and Modal Analysis Method shows good results in prediction the vibration response.
3. Inter-modulation effect plays a crucial role in predicting the non-linear vibration response. This phenomenon can be shown clearly as a rotating system excited by unbalance and misalignment excitation force, which the summation of both excitation frequencies close to the natural frequency of the system.

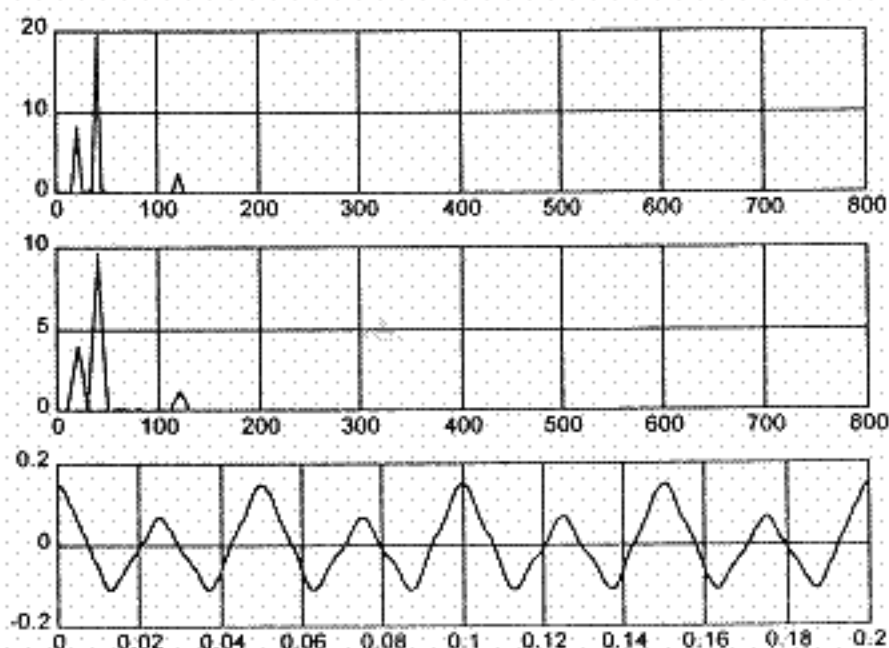

Figure 11. Theoretical analysis of vibration response caused by unbalance (80 grams, 20 Hz) and misalignment

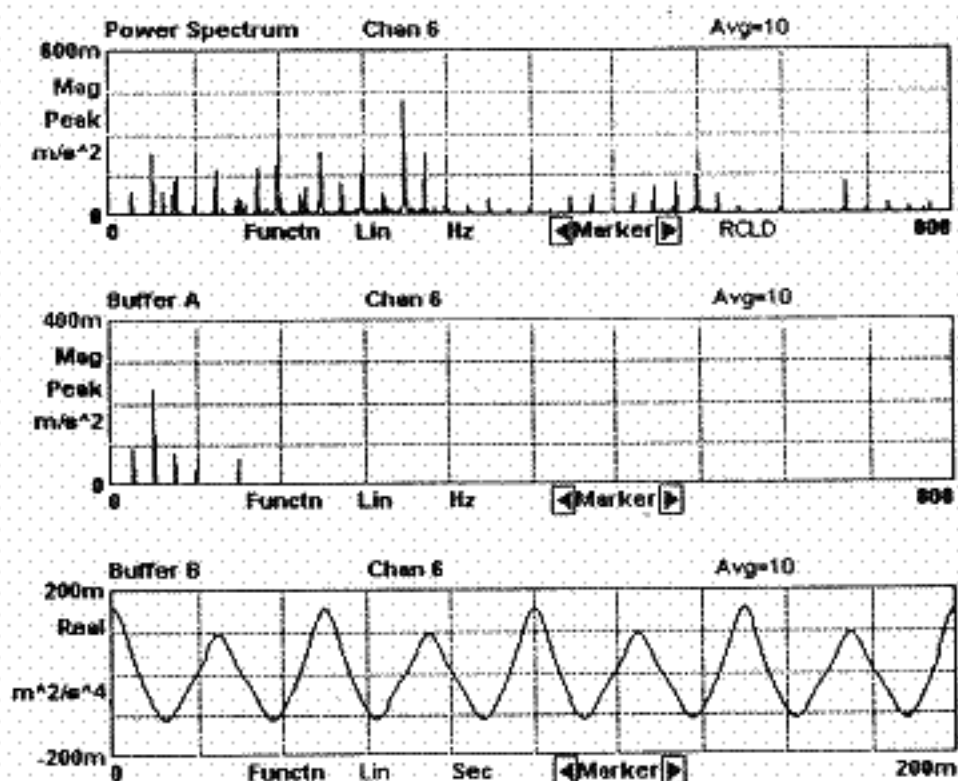

Figure 12. Experimental result of vibration response caused by unbalance (80 grams, 20 Hz) and misalignment

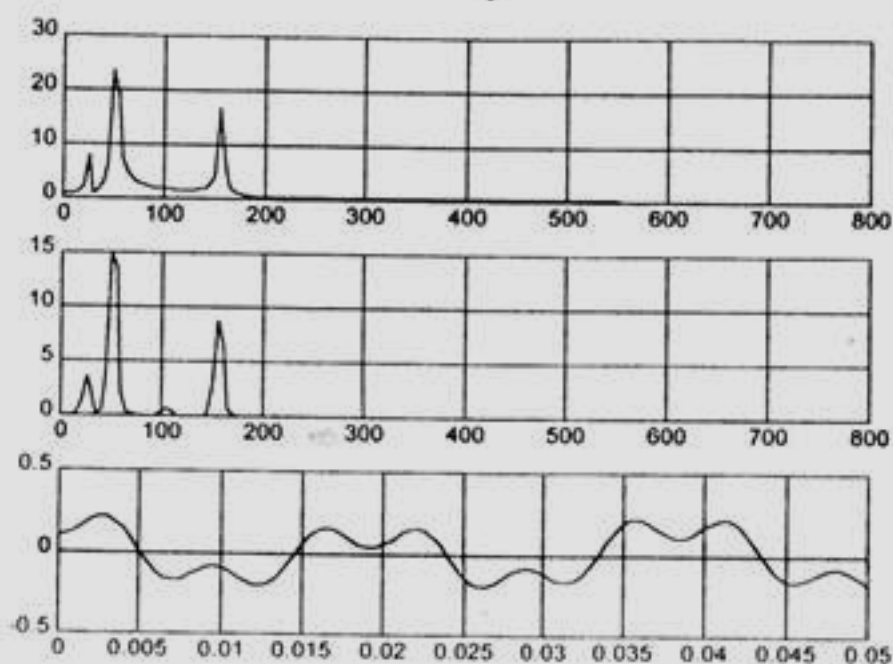

Figure 13. Theoretical analysis of vibration response caused by unbalance (80 grams, 26 Hz) and misalignment

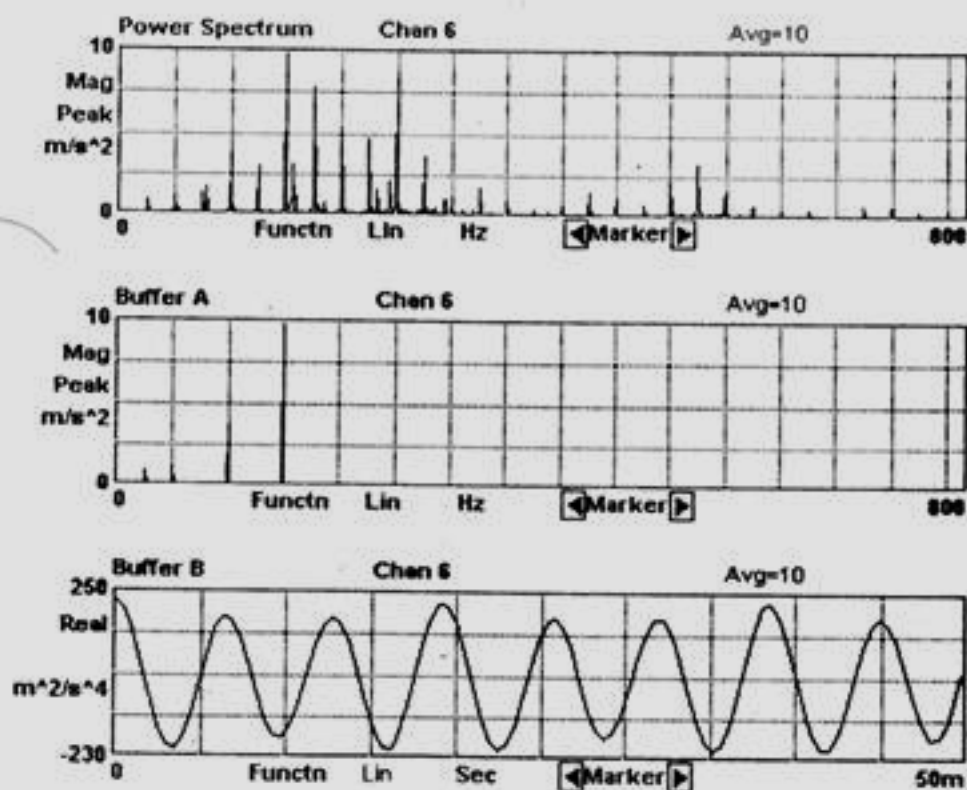

Figure 14. Experimental result of vibration response caused by unbalance (80 grams, 26 Hz) and misalignment

Acknowledgement

This paper is a part and related to the main research program entitled 'Mechanical Signature Analysis of Synchronous and Asynchronous Excited Rotating Rotor Supported by Rolling

Element Bearings'. The program is financed through Graduate Team Research Grant from the Directorate General of Higher Education, Ministry of Education and Culture, the Republic of Indonesia. Research contract no. 018/HTTP/II/URGE/1996.

References

1. Irwanto, *Kaji Teoritik dan Analisis Respon Getaran Sistem Poros Rotor yang Ditumpu oleh Bantalan Rol*, Tesis Magister, Jurusan Teknik Mesin ITB, Oktober 1997.
2. Schetzen, M., *The Volterra & Wiener Theories of Nonlinear Systems*, John-Wiley and Sons, 1980.
3. Tjahjowidodo, T., *Kaji Teoritik dan Analisis Respon Getaran Non-Linier pada Sistem Poros-Rotor menggunakan Deret Fungsional Volterra*, Tesis Magister, Jurusan Teknik Mesin ITB, Oktober 1999.
4. Peyton, J.J.C., Billing, S.A., *Interpretation of Non-Linear Frequency Response Function*, International Journal of Control 2, 52 (1990), 319-346.
5. Storer, D.M., Tomlinson, G.R., *An Explanation of the Cause of the Distortion in the Transfer Function of a Duffing Oscillator Subject to Sine Excitation*, Proceeding 10th International Modal Analysis Conference, Florence, Italy, 1991.